



DEH-1700P

Air dehumidifiers

» Operation manual





CONTENT

Air dehumidification.....3

Precautions7

Dehumidifier description.....8

Location and functions.....8

Dehumidifier design.....12

Control panel.....13

Start up and operation.....15

Specifications.....20

Support and warranty.....21



**This instructions manual should always be near
or on the unit!**

AIR DEHUMIDIFICATION

The moisture from the basin surface (evaporation) is absorbed by the ambient air. Thus, this increases the air humidity and ultimately results in corrosion, mould, rot, peeling of paint coatings and other unwanted damages.

The below diagram shows an example of metal corrosion rate at different air humidity levels.

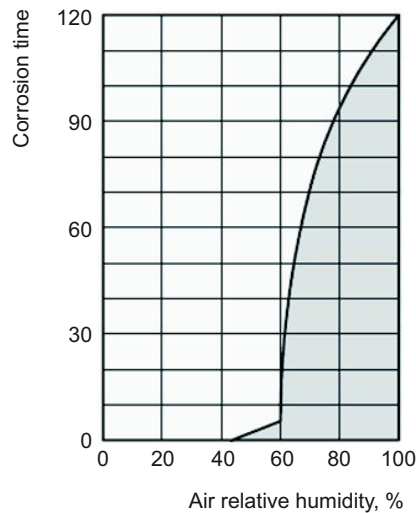

As you can see the rate of corrosion is insignificant at the relative humidity (RH) below 50%, and it can be disregarded at RH below 40%. But at the relative humidity above 60% the rate of corrosion increases considerably. This moisture damage example applies also to many other materials, such as powders, packaging, wood, electric equipment or electronic devices.

There are two different ways of buildings drying out:

1. By heating with further air exchange:

The ambient air is heated to absorb the moisture and then it is discharged to the atmosphere. However the total energy output is lost during the moist air discharging to the atmosphere.

2. By the air dehumidification:

The moist air in an enclosed room is continuously dehumidified by the condensation principle. In terms of energy consumption the air dehumidification has one essential advantage: The energy expenditure requirements are limited by the air volume in the existing room only. The mechanical heat released during the dehumidification process slightly increases the air temperature in the room.

When properly used the dehumidifier consumes about 25% of the energy that would be needed for the „heating and ventilation“.

The relative air humidity

The ambient air is a gas mixture that always contains a certain amount of water in the form of water vapor. This water percentage is expressed in g per kg of dry air (absolute water content). 1 m³ of dry air weighs about 1,2 kg at 20° C. Depending on the temperature each kg of the air is only able to absorb a certain amount of water vapor. When this absorptive capacity is reached the air becomes "saturated" and the relative humidity becomes 100%. The relative humidity is understood to be the ratio between the water vapor percent currently contained in the air and the maximum water vapor percent at the same temperature. The ability of air to absorb water vapor increases with temperature increasing. This means that the maximum (= absolute) water content increases with temperature increasing.

Temp. °C	Water vapor content in g/m ³ in the air at the humidity of			
	40%	60%	80%	100%
-5	1,3	1,9	2,6	3,3
+10	3,8	5,6	7,5	9,4
+15	5,1	7,7	10,2	12,8
+20	6,9	10,4	13,8	17,3
+25	9,2	13,8	18,4	23,0
+30	12,9	18,2	24,3	30,3

Water vapor condensation

The maximum water vapor volume that can be absorbed increases when the air is heated, but the water vapor content remains however the same and this results in relative humidity reduction. In contrast, when the air is cooled, the maximum water vapor volume that can be absorbed continuously reduces, the water vapor volume contained in the air remains however the same and the relative humidity increases. If the air temperature falling continues the capacity to absorb the water vapor volume is reduced until it is equal to the water vapor content. This temperature is called the dew-point temperature. When the air is cooled below the dew-point temperature, the water vapor content becomes higher than the maximum possible water vapor content.

Water vapor displacement starts.

The vapor condenses to water. Thus the moisture is removed from the air. A misted window glass in winter or a misted bottle with a cold drink are common examples of condensing. The higher the relative air humidity the higher is the dew-point temperature, and thus it is easier to fall below the dew-point temperature.

The produced condensate is collected in the unit and discharged.

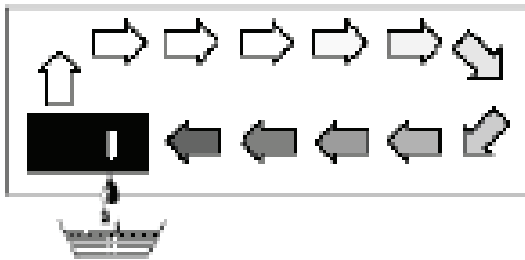

The air flow is cooled on the way through /via the evaporator-condenser till its temperature is below the dew point. Water vapor condenses, it is collected in a condensate trap and discharged.

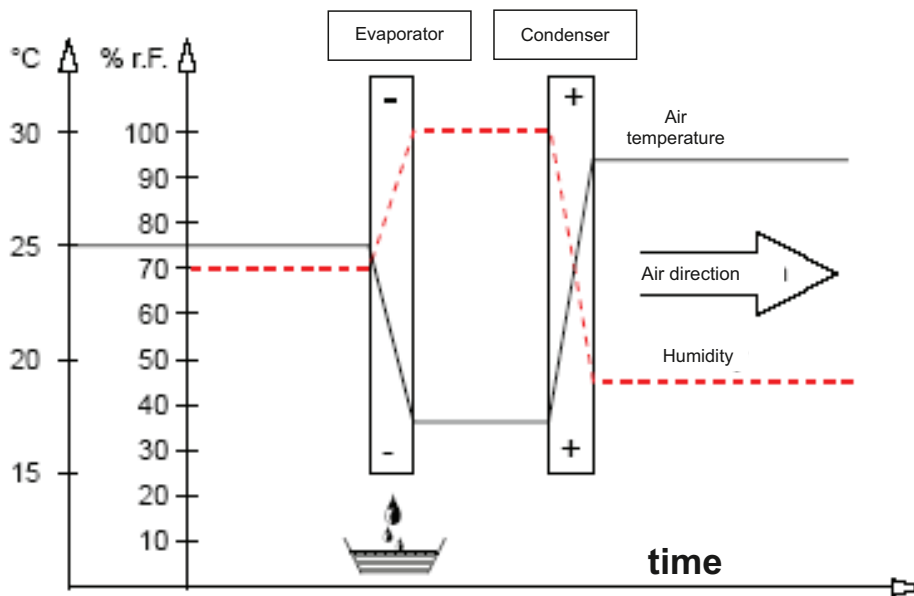

Heat of condensation

The energy transferred from the condenser to the air consists of: The heat earlier transferred from the evaporator. Real electrical power. The heat of condensation released through the condensation of water vapor. When liquid turns into a gaseous state, the energy should flow in reverse. This energy is called the heat of evaporation. It does not cause any rise of temperature, it is only necessary for the change from a liquid to a gaseous state. Vice versa, the energy is released when gas turns into liquid, such energy is called heat of condensation.

The heat generated at condensation and evaporation and is identical. For water this is 2250kJ/kg (4.18kJ = 1kcal). This shows that a relatively large amount of energy is released in the process of water vapor condensation. If the moisture to be condensed is not generated at evaporation in the room but is introduced from outside, e.g. via ventilation, the heat of condensation released in the process will be used for the room heating. If it is required to dry materials or rooms the heat energy recirculates, i.e. it is consumed during evaporation and is released during condensation. A large amount of heat energy is generated at the supplied air dehumidification process, which is expressed as a rise of temperature. Normally the time necessary for drying does not depend only on the unit capacity, but is determined by the rate at which the material or the building elements release the moisture they contain.

SAFETY PRECAUTIONS

1. Read these operations instructions carefully before operating the dehumidifier.
2. Never immerse the unit into water or other liquids.
3. Never use the unit if its cable or power plug is damaged.
4. Electrical devices can be repaired by qualified personnel only, improper repair can be a source of serious danger for users.
5. Children are not aware of the unit hazard. Never let children operate electric devices if they are not under proper control.
6. It is required to disconnect the unit from the power supply when it is out-of-operation and before its cleaning.
7. The unit should be used only with the voltage specified in the table.
8. Please note that this unit is designed for domestic use only. It is intended for household needs.
9. It is not allowed to put heavy objects on the dehumidifier.
10. Before transportation make sure that the condensate tank is empty to prevent water leakage.
11. The unit is not intended for use by physically or psychically limited persons (including children) or by those who have no experience or were not instructed by the persons responsible for their safety. Children should be under supervision to assure they do not play with the unit.
12. If the power cord is damaged it should be replaced by the manufacturer, service center or similar qualified specialists to avoid danger.
13. It is prohibited to use the unit in the locations where chemical substances are used.
14. Before cleaning the unit should be switched off.

DEHUMIDIFIER DESCRIPTION

The unit is designed for automated, versatile and trouble-free air dehumidification. The unit operates on condensation principle. It is equipped with a closed loop cooling system, low noise and low maintenance fan and with a power cable with a plug. The unit's control panel is equipped with an LCD-display used for the system functional checks. A fully automated unit control system, a trouble-free regulated humidistat, an integrated overflow system as well as flexible hose connection for direct condensation discharge assure fail safe and long-term operation of the unit.

The unit complies with the fundamental safety and health requirements of the existing EU regulations. The unit is easy and safe to operate.

Unit location

The unit is operated in the buildings where dry air is necessary to prevent significant financial losses (for example, due to mould formation). The unit is mainly used for drying and dehumidification in saunas and basins. It is also used for dry air maintenance in storage areas, archives, laboratories, bathrooms, laundries, changing rooms etc.

Functions

The unit operates on condensation principle.

The fan

The fan intakes moist surrounding air into the units front side through the air filter, evaporator and condenser. The heat is extracted at the cold evaporator. The air is cooled to below the dew point. The water vapor contained in the room air deposits as condensate or frost on the evaporator fins. Dried and cooled air is heated in the condenser (radiator) again. Then it is discharged to outside, the air temperature is about 5 degrees higher than the room temperature.

The dried air is mixed with surrounding air again.

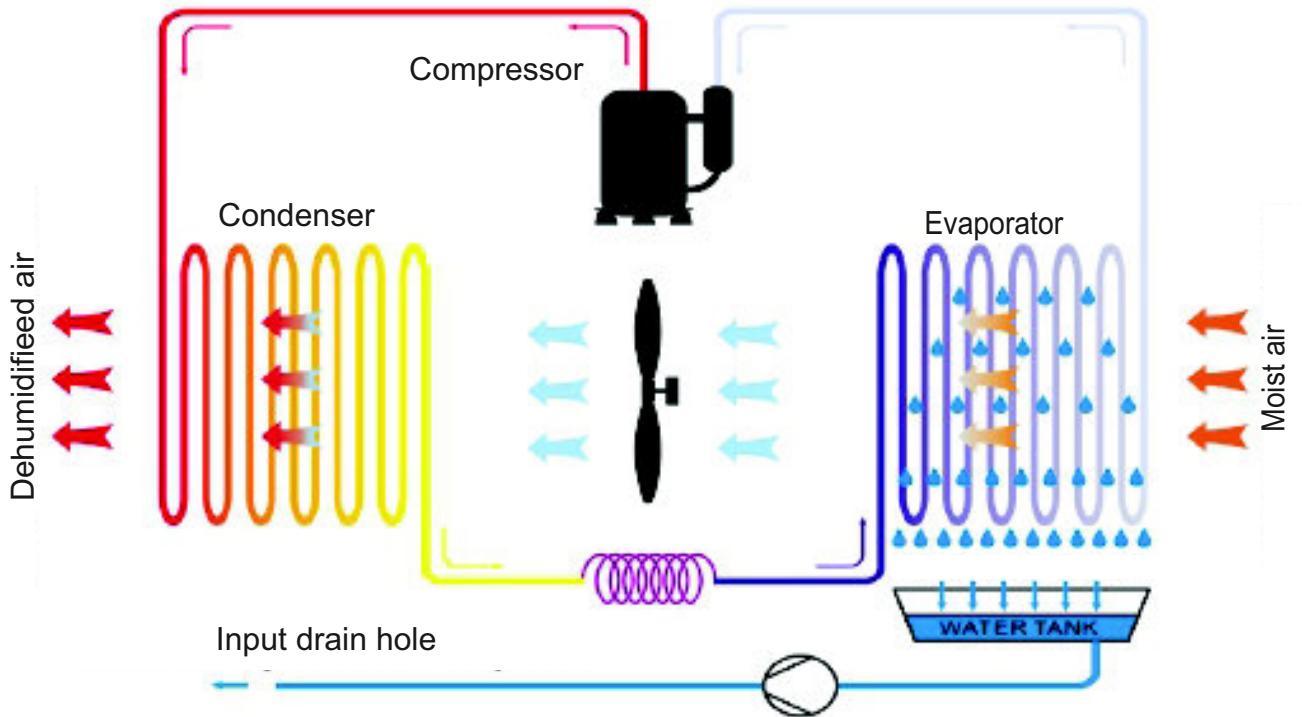

The relative humidity gradually drops to the required RH value due to continuous outside air circulation through the unit.

Depending on the room temperature and relative humidity the condensed water drips into an condensate tray (inside the system) through integrated drain channels. Then the water is pumped to outside via a drain tube.

Installation

For optimum, economical and safe unit operation the following instructions must be followed:

1. The unit must be installed securely upright to ensure unhindered condensate discharge through a drain tube.
2. It must be ensured that the air is able to be sucked in freely at the front of the unit and to be discharged through the top part of the air throttle.

It is prohibited to locate the unit in close proximity to radiators and other heat sources.

Important information on electrical connections

Electric wiring of the unit should be done in accordance with DIN VDE 0100, Part 704 for electric current supply sources equipped with automatic circuit-breakers. If the unit is installed in humid premises such as saunas or basins it should be equipped with proper automatic circuit-breakers at the buyer's expense.

Commissioning

Prior to commissioning works or to comply with local requirements it is necessary to check air intake openings and outlet openings to be sure that they are free from foreign matters. Intake filters condition should be checked as well.

The following instructions are to be observed:

1. Extension cables should be of proper cross-section.
2. It is allowed to use extension cables if they are fully disentangled or stretched!
3. It is not allowed to pull the unit by the power cord.
4. Upon actuation the unit operates in fully-automatic mode.
5. The unit is equipped with a protection device that prevents the compressor from switching on at restart immediately after the unit switching off, thus preventing the compressor damage. The compressor switches on after 3 minutes only.

We do not ensure the efficient operation of the unit if the room temperature is below 6°C and if the relative humidity is below 40 %.

Unit mounting is usually executed along the wall. Humidifier comes standard with mounting angles to fix the humidifier to the wall as shown at Fig.1 and Fig.2.

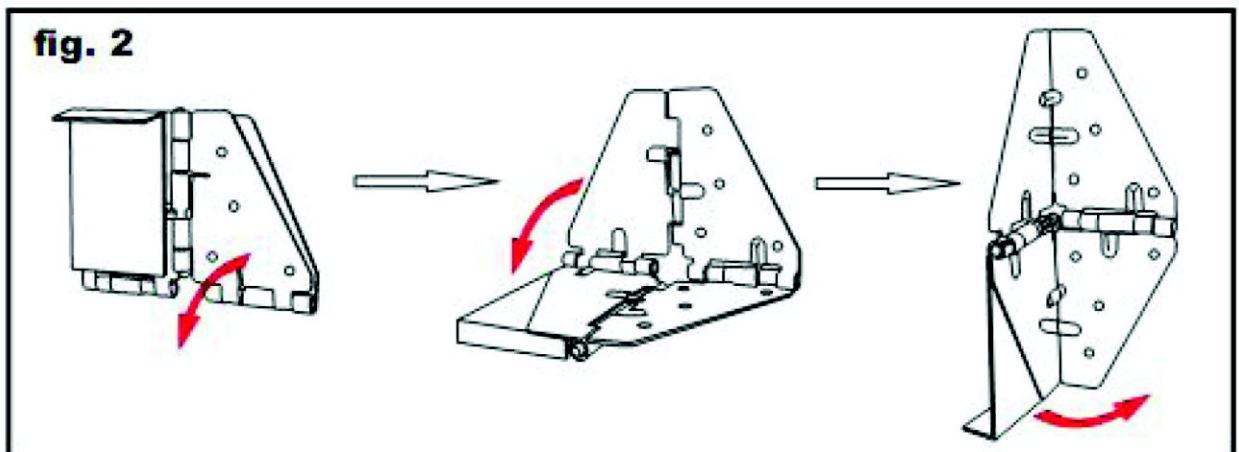
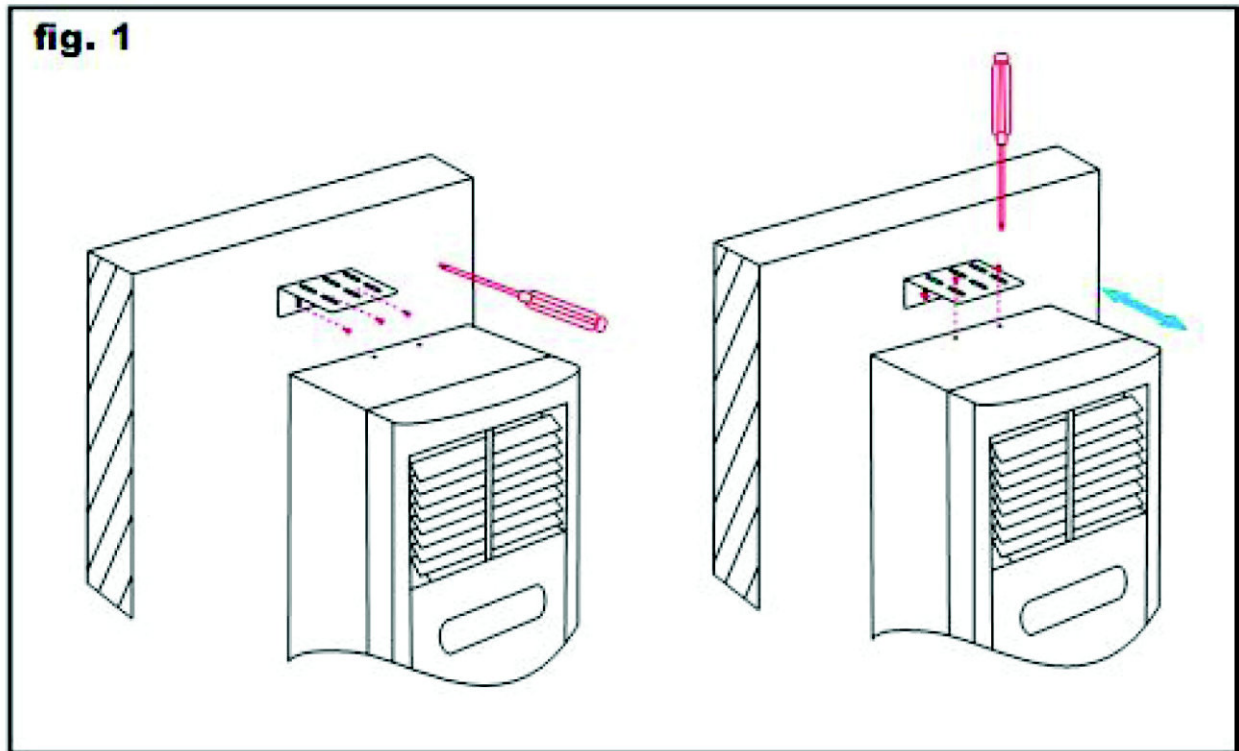

DEHUMIFIER DESIGN



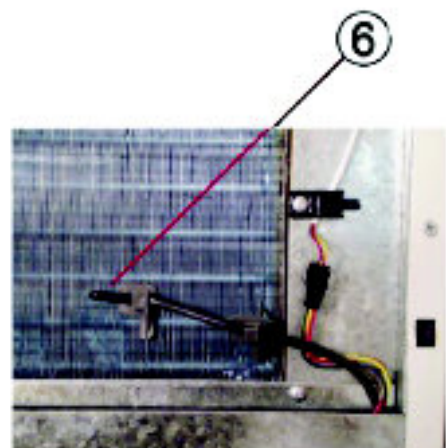
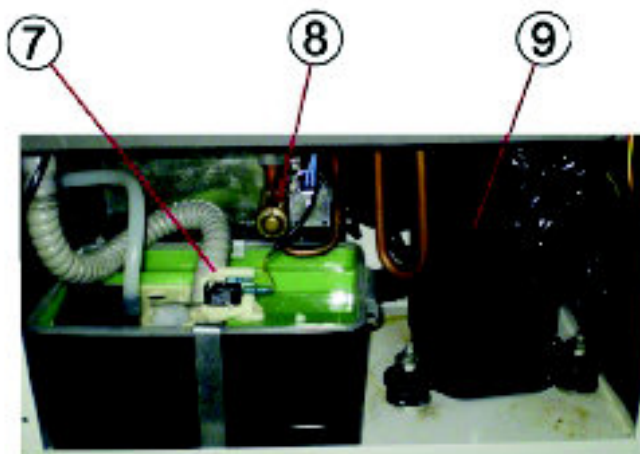
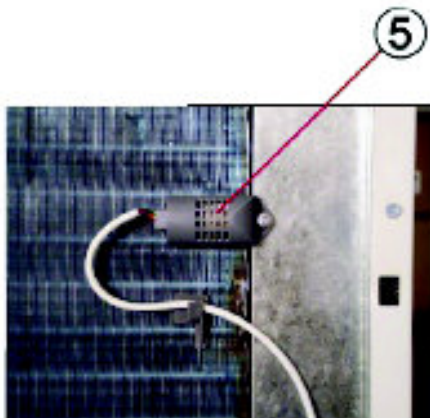
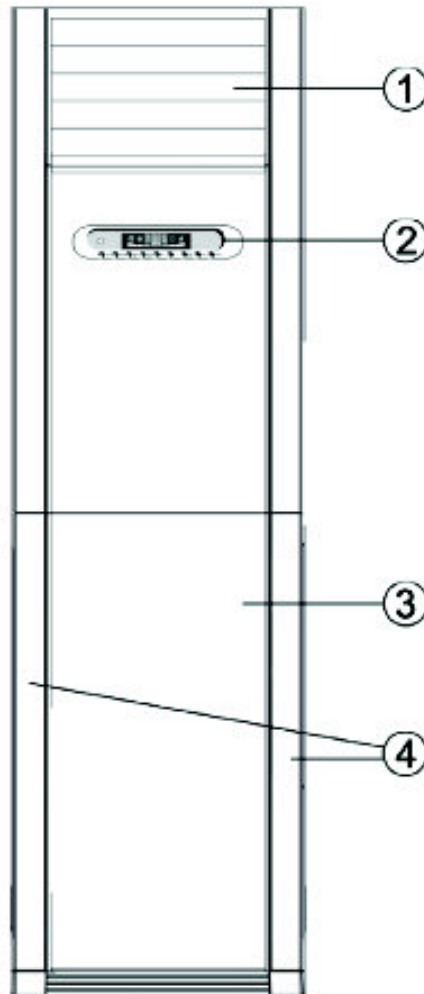



- 1) Dehumidified air outlet
- 2) Control panel
- 3) Air filter (inside)
- 4) Air intake
- 5) Humidity sensor
- 6) Temperature sensor
- 7) Collecting drain pan
- 8) Valve
- 9) Compressor

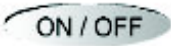

Control panel

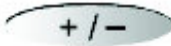

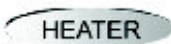
Buttons

- | | | | |
|--|--|--|---|
|  | ON/OFF button |  | Mode selection button (auto, dehumidification, ventilation, heating opt.) |
|  | FAN SPEED (high, moderate, low) control button |  | Humidity control button |
|  | Vertical louvers ON/OFF button |  | Horizontal louvers ON/OFF button |
|  | Air heating button (option) |  | Timer button |

Display

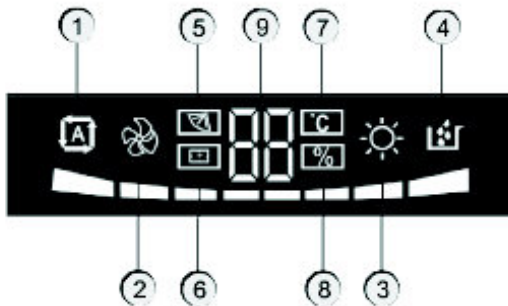

- | | | | |
|---|--------------------------|---|-------------------------------------|
|   | Auto mode |   | Timer indicator |
|   | Ventilation mode |   | Temperature indicator |
|   | Heating mode |   | Humidity indicator |
|   | Dehumidification mode |   | Timer, temperature, humidity values |
|   | Heating element (option) | | |

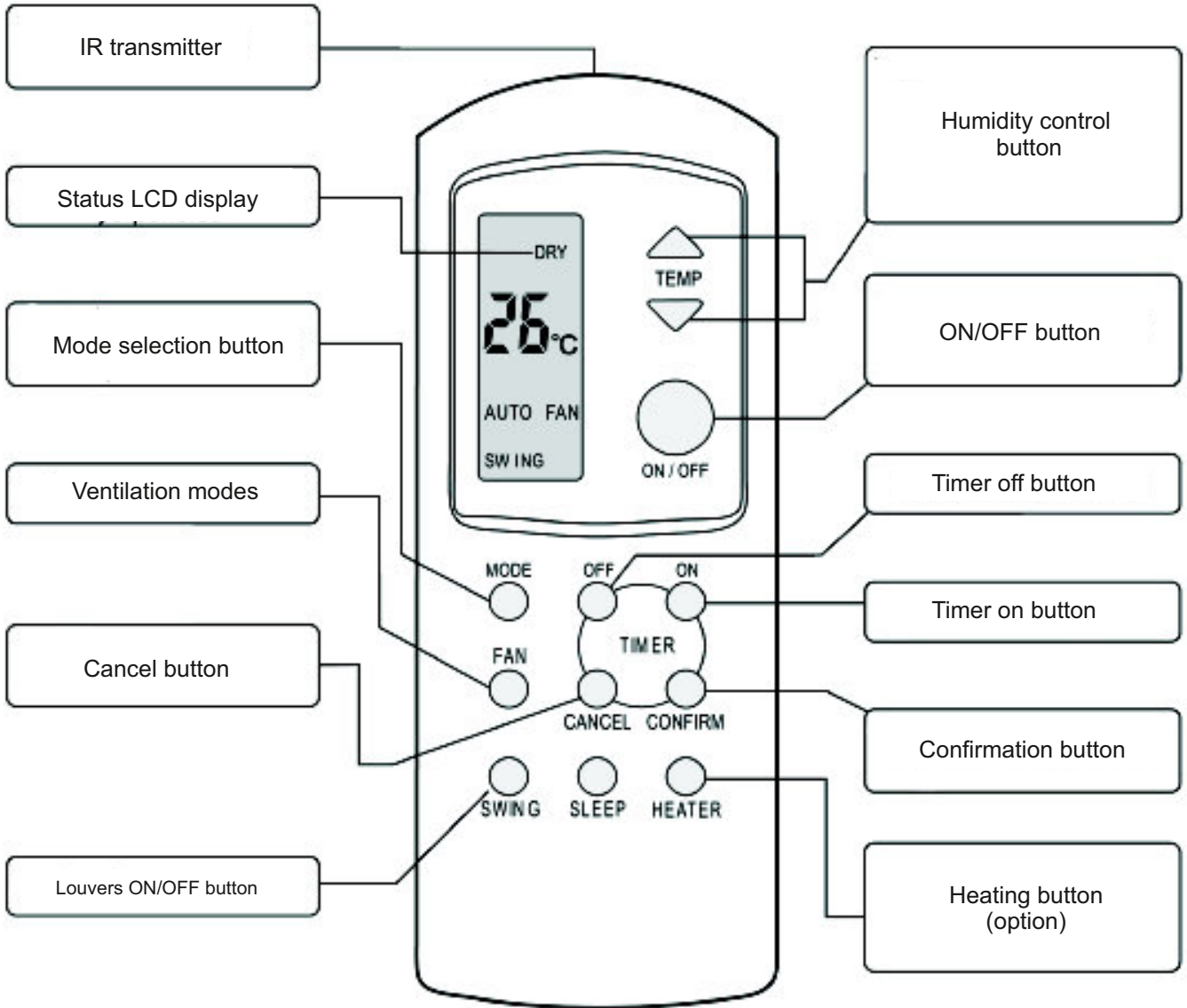

Startup and operation

Mode selection (1)

To set the necessary mode press the “MODE” button
Auto > Dehumidification > Ventilation > Heating

Attention:

- Heating mode is available only at the models equipped with the heating element.

Air flow selection (2)

Press the “FAN” button to set the air flow.
Each pressing changes the fan speed.

Auto > Low > Moderate > High

Attention:

- In “Auto FAN” mode the dehumidifier selects the optimum speed depending on the room temperature.
- In “Dehumidification” mode the fan speed button is not active.

Temperature setting (3)

Press Up or Down buttons to select the necessary temperature from + 16C to 31C.

Dehumidifier startup (4)

Press “ON/OF” button and the panel will send the set information. The dehumidifier will start working after two audio signals.

Attention:

- In case of the repeated startup you can skip the steps 1 – 3 if the fan and temperature parameters are not to be changed.
- In case of the repeated switching on the compressor will start not earlier than in 3 minutes after the humidifier switching off.

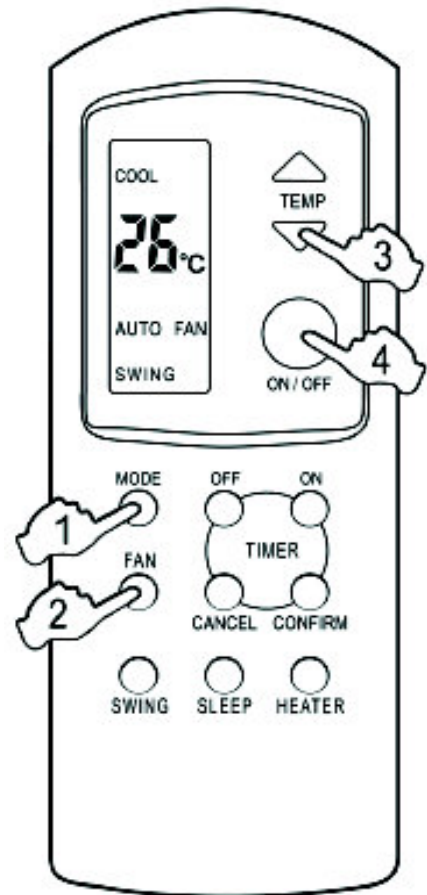

Auto mode

- (1) Select the Auto mode by pressing the “MODE” button.
- (2) Set the necessary level of the fan.
- (3) Press “ON/OFF” button to start the dehumidifier in the Auto mode.

Attention:

In the auto mode the dehumidifier sets the Dehumidification mode, Heating mode by itself depending in the room temperature and humidity according to the table:

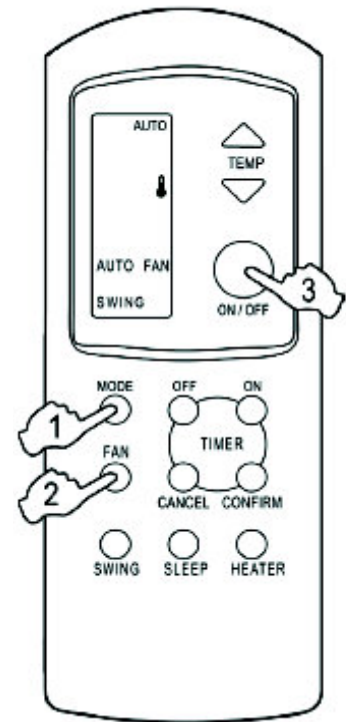

Mode/Temperature	<23°C or >28° humidity >80%	23°C ~28°C	<23°C or >28°C humidity <80%
Dehumidification	Operating	Operating	Not operating
Heating	Not operating	Not operating	Operating

In Auto mode the dehumidifier works only if it's equipped with the optional heater (heating element).

Louvers

Horizontal louvers

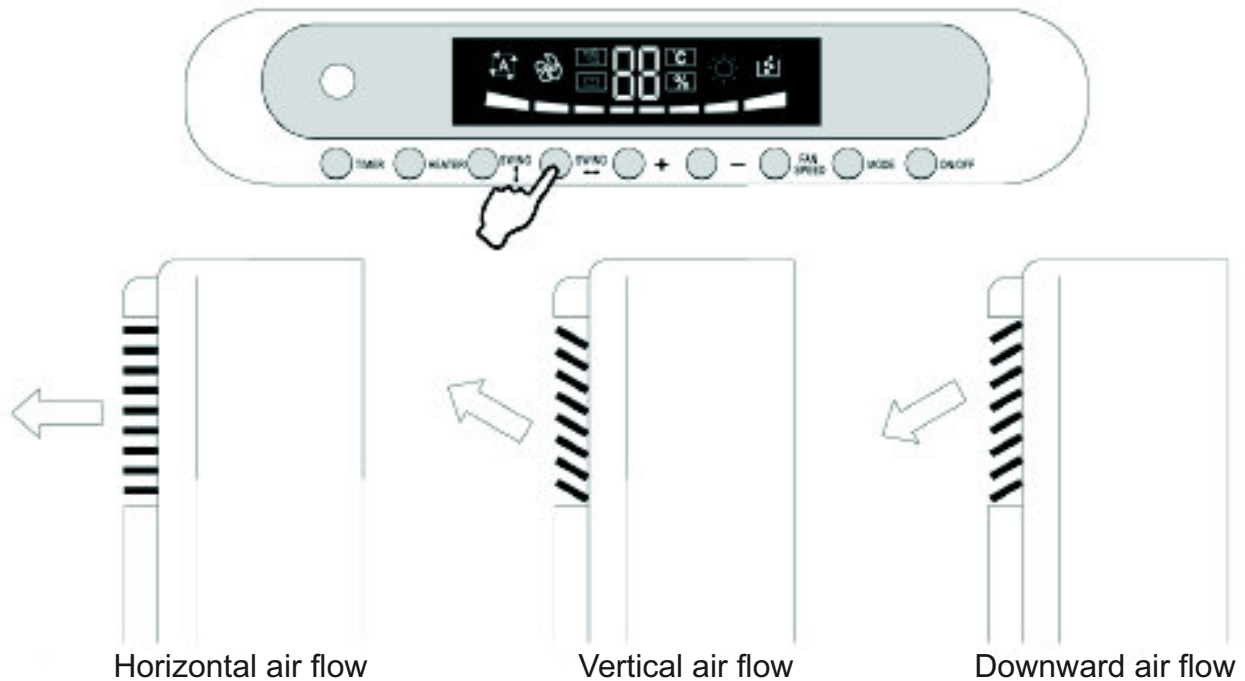

Attention:

- Louvers can be fixed in the required direction. Use the “SWING” button on the dehumidifier panel to turn it on/off.
- To provide the better effect it's recommended to install the shutters horizontally in the dehumidification mode and downwards in the heating mode.

Vertical louvers

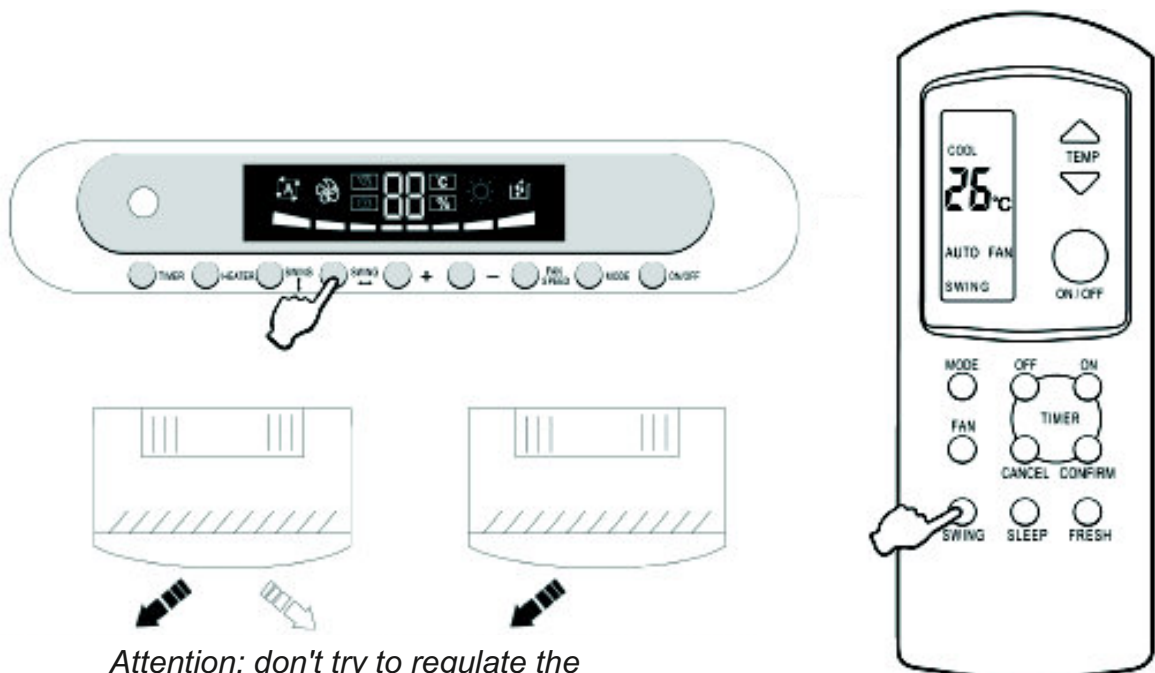

Attention: don't try to regulate the air flow louvers manually

Wiring diagram

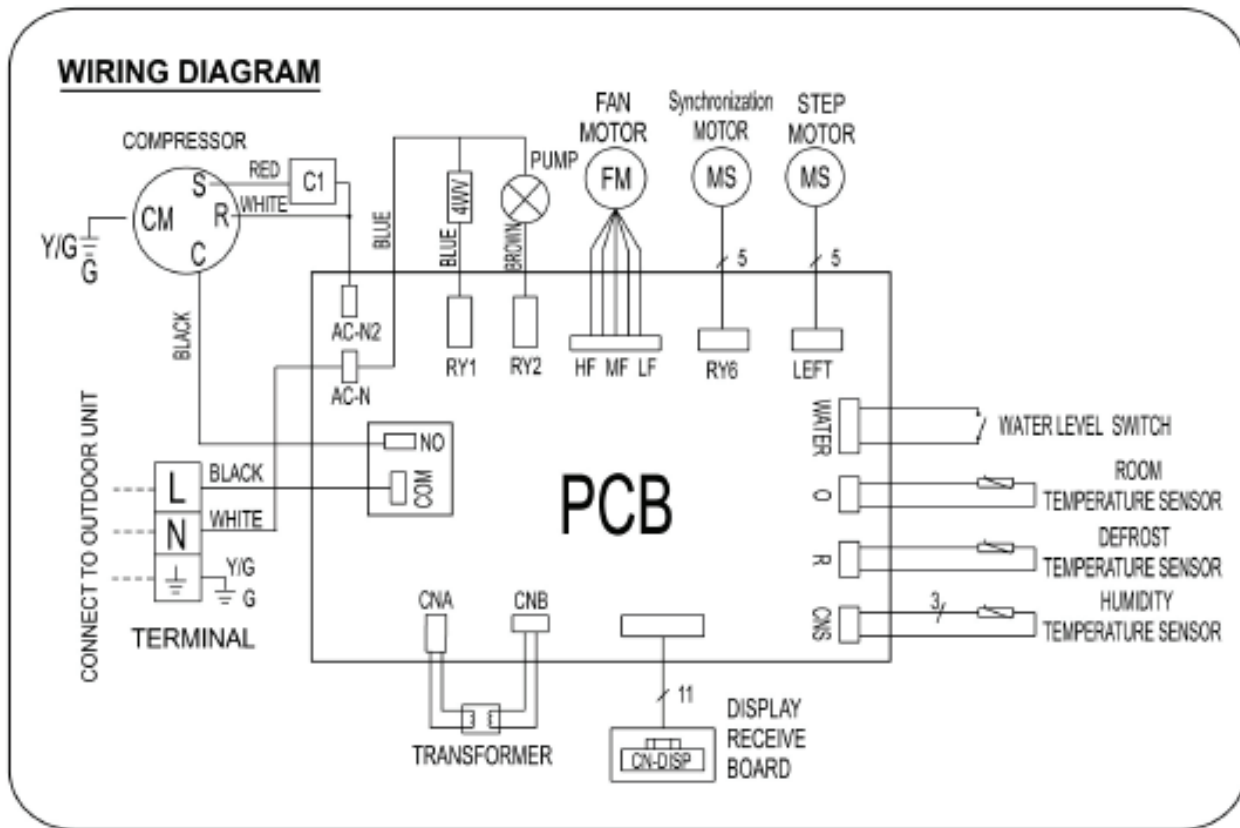

- | | |
|--------------------------------------|-----------------------------|
| 1) Upper trim panel | 20) Mounting low panel |
| 2) Lower trim panel | 21) Compressor |
| 3) Control panel | 22) Valve |
| 4) Rear housing panel | 23) Automatic drain system |
| 5) Left housing panel | 24) Drain tube |
| 6) Upper housing panel | 25) Transport wheel |
| 7) Condenser | 26) Transport wheel |
| 8) Mounting angle | 27) Condenser |
| 9) Electric heating element (option) | 28) Contact bank |
| 10) Right housing panel | 29) Motor condenser |
| 11) Крыльчатка вентилятора | 30) Controller PCB |
| 12) Cover | 31) Transformer |
| 13) Fan impeller | 32) Dehumidifier controller |
| 14) Motor fixation panel | 33) Sensor |
| 15) Fan case | 34) Mounting stop angle |
| 16) Evaporator | 35) Filling nipple |
| 17) Condensate collecting pan 1 | 36) Humidity sensor |
| 18) Condensate collecting pan 2 | 37) Temperature sensor |
| 19) Lower trim panel | 38) Electric wire |

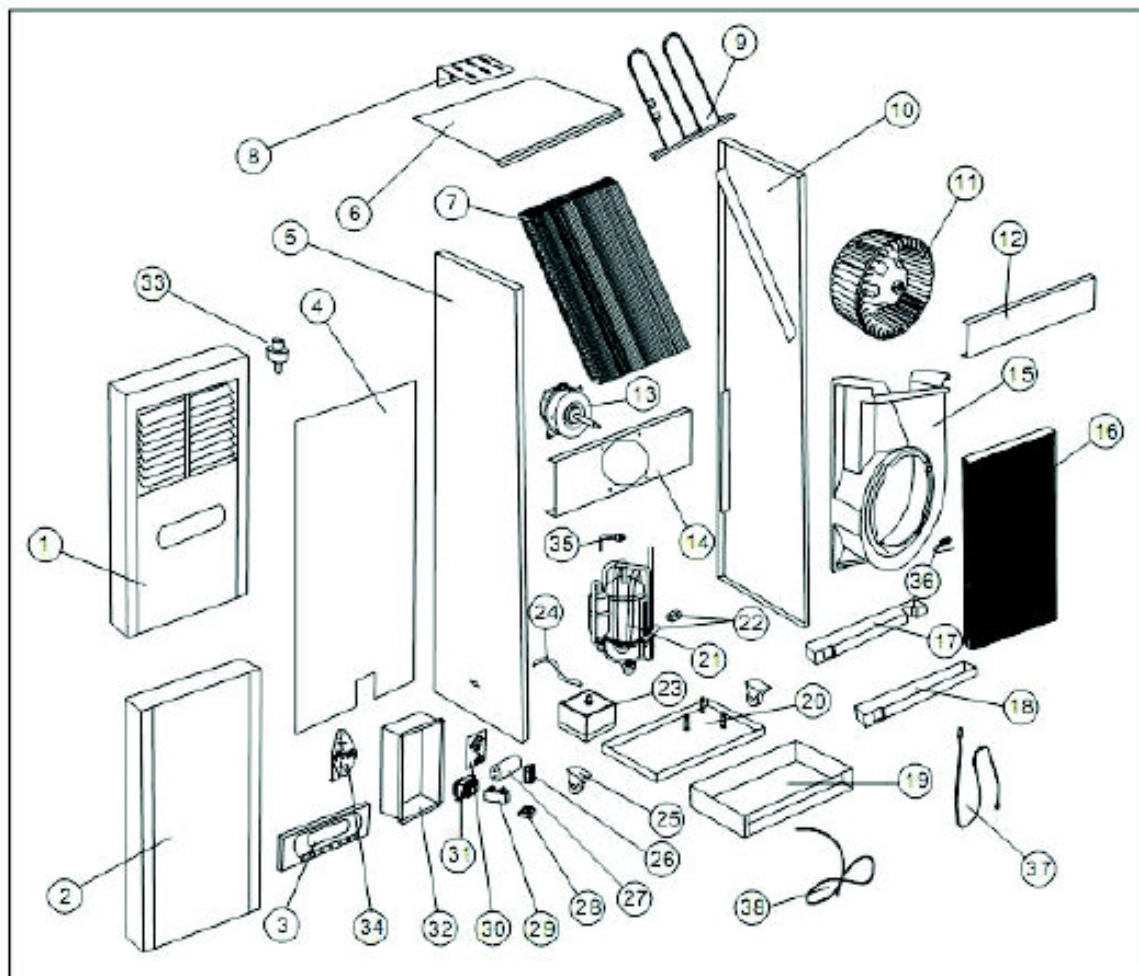

SPECIFICATION

Characteristics	Model	DEH-1700p
Power supply		220-240V-50HZ
Consumed power		1,65 kW
Operating current		4.9 A
NET weight		86 kg
GROSS weight		94 kg
Moisture removal at - (30°C / 80%)		163.2 l/day
Air consumption		1100m3/hour
Dimensions (HxDxW)		1720 mm x 420 mm x 480 mm
Temperature range		6°C~32°C
Operating humidity		30-100%
Noise level		48 dB (A)
Refrigerant		R410C

(CE) N 842/2006: R410A is a kind of fluorinated greenhouse gases covered by the Kyoto Protocol. Its total global warming potential (GWP) is 1975.



This marking indicates that this product should not be disposed with other household wastes throughout the EU. To prevent possible harm to the environment or human health from uncontrolled waste disposal, recycle it responsibly to promote the sustainable reuse of material resources. To return your used device, please use the return and collection systems or contact the retailer where the product was purchased. They can take this product for environmental safe recycling.

Warranty obligations

DanVex warrants that all the equipment parts will answer the technical requirements for 12 months from the date of delivery (warranty period).

The warranty does not cover wearable parts such as filters. The warranty covers the defects in workmanship and materials.

During the warranty period DanVex repairs and replaces the part having a defect of material or an manufacturing error.

DanVex completely fulfills its warranty obligations when it supplies the Customer a repaired or a spare part.

Parts repair or replacement does not result in the warranty period extension.

The parts and components replaced under the warranty belong to DanVex.

DanVex or its distributor upon DanVex request has a right to inspect the defective parts and to check the correctness of the warranty claim.

Warranty repair execution conditions:

The damage occurred during the equipment normal operation. All recommendations and instructions of the manufacturer concerning the equipment installation, operation and maintenance were observed. Only original parts and materials were used for the equipment maintenance and repair.

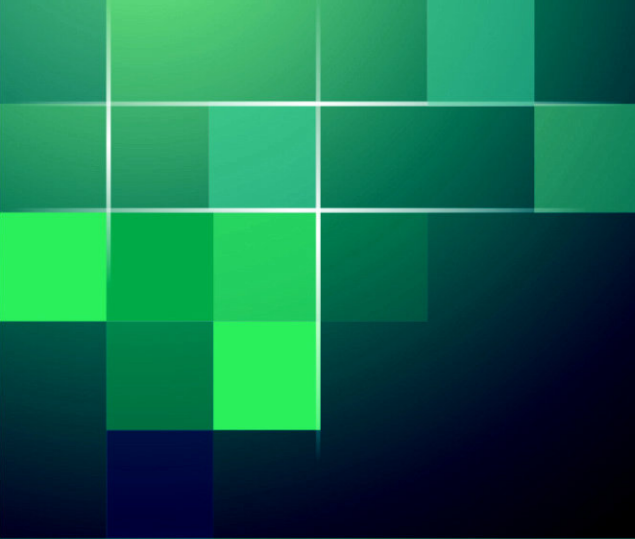

www.danvex.fi

